

# SINGLE-SHAFT-SHREDDER

## TARGO 3000 XD TRACKED



### EXTRA DUTY

The TARGO 3000 XD - where XD stands for eXtra Duty.

With a weight of 35 tons, the XD is the real heavyweight champion within its class. The custom-built heavy duty three-stage direct drive gearbox transfers even more torque to the shredder shaft.

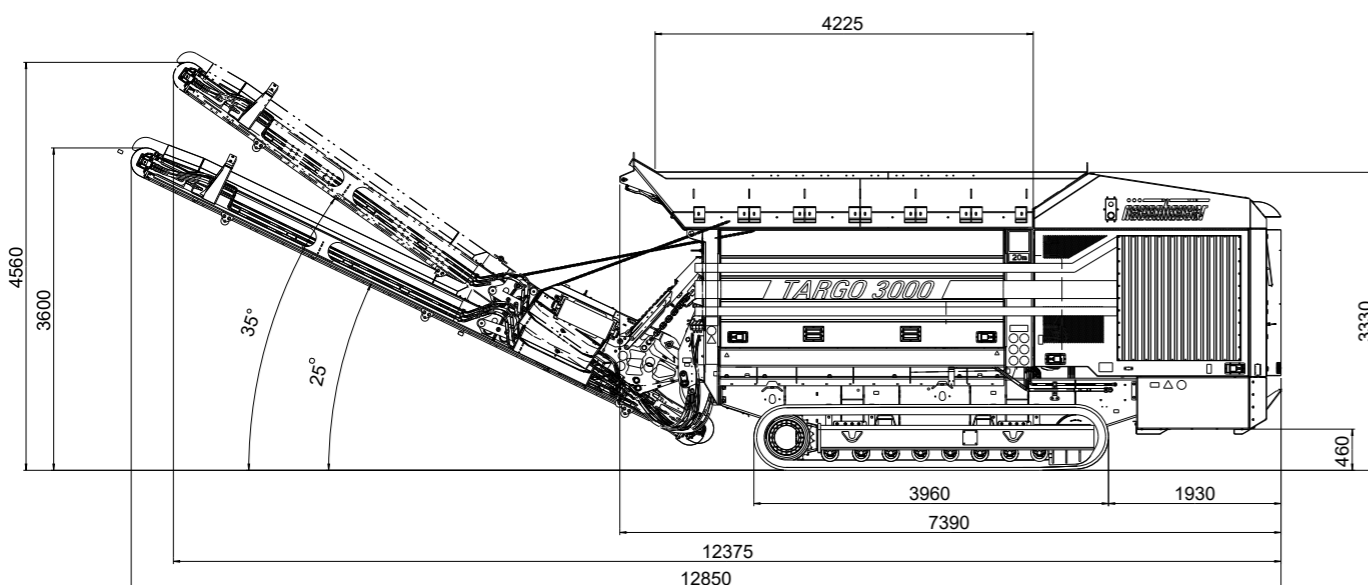
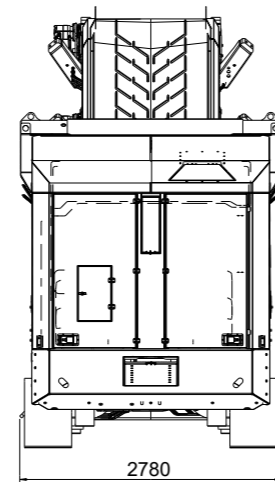

Self-driving tracked chassis frame; with two variable driving speeds

Total weight	approx. 35,000 kg	
<b>Drive</b>		
Engine type	Diesel direct drive, Volvo Penta TAD 1374 VE	
Power	375 kW	
Exhaust emission standard	In accordance with the latest emission standard	
Engine displacement	13 litre	
Fuel tank	approx. 500 litre	
<b>Shaft</b>		
Length	3,000 mm	
Diameter	600 mm	
Rotation speed	max. 34 rpm	
Qty. of teeth	21 (optionally 42 teeth)	
<b>Comb</b>		
Length	3,000 mm	
Qty. of teeth	20	
	<b>Discharge conveyor belt</b>	<b>Collecting conveyor belt</b>
Belt width	1,200 mm	1.000 mm
Length	5,040 mm (optionally 7,500 mm)	3.335 mm

